

Speed Queen®

Multi-Housing



EcoWatersaver™

Card Ready

SFNNYRSP111TW01

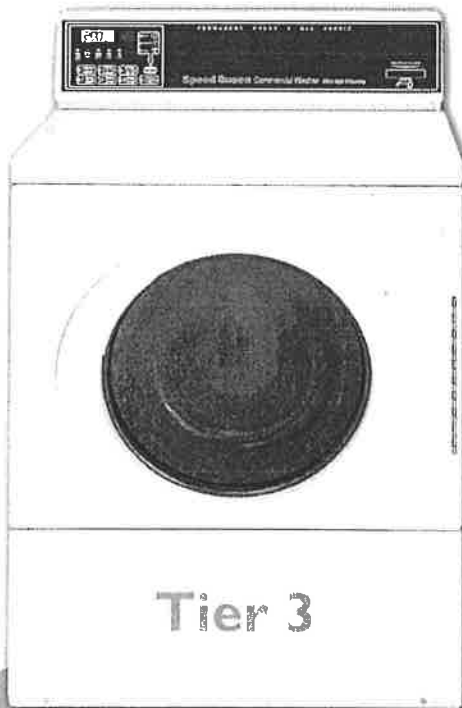

Commercial Heavy-Duty Rear Control Front Load Washer

Description

- Tier 3 rated 10.9 gals
- Extra-large digital displays
~ Vend price preset \$2.00
- LED cycle status indicator
- Touch pad control with sound indicator
- Control panel selection 27 cycle and pricing options
~ Normal, Perm Press and Delicate Cycles
~ Hot, Warm and Cold Wash Fill
~ Heavy, Medium or Light Soil Levels
- Infrared two-way communications with pocket PDA
- Bonus revenue streams
~ Premium wash cycle
~ Time-of-day promotions
~ Multi-level vending H - \$2.50, W - \$2.25, C - \$2.00
- Secured automated audits
~ Cycle and card pulse counts
~ Verifies collection activity
- **Activation - Card**

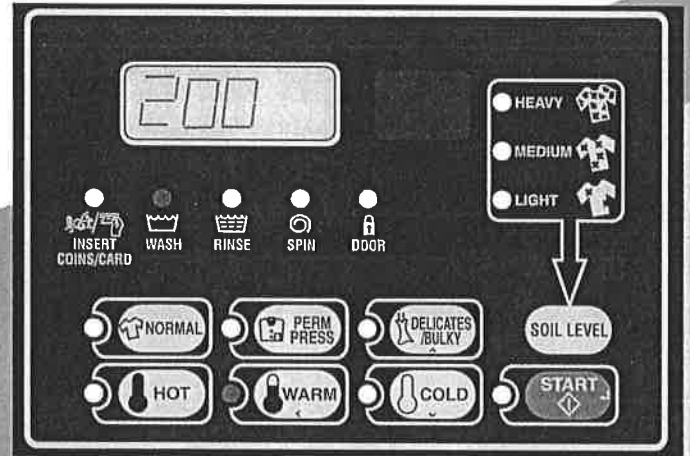

Nobody Compares with Speed Queen Quality

- Multi-compartment supply dispenser. Automatically adds detergent, liquid bleach and liquid softener.
- High speed extract. 1000 RPM final spin extract maximizes water removal from clothes for faster drying.
- Stainless steel washtub.
 - Full length stainless steel baffles maximizes clothes turn for better washing.
- Includes mini guard perforated holes for expedient wash and drain operation.



- Large "big load" 15½" door opening with see-through glass.
 - Heavy-duty 10" piano hinge door.
 - Door swing 180°.
- Americans with Disabilities Act (ADA) compliant with side reach exception for 36" over obstruction cabinet top.
- Department of Energy compliant for energy and water standards.
- ENERGY STAR® qualified.
- Modified Energy Factor (MEF) 2.46 ft³/kWh/cycle.
- Water Factor (WF) 3.83 gallons/ft³.



Commercial Built to Last Longer

Specifications

Model	SFNNYRSPI11TW01
Width - in (mm)	26 7/8" (683)
Depth - in (mm)	28" (711)
Height - in (mm)	43" (1092)
Cabinet Height - in (mm)	36" (910)
Cylinder Volume (capacity) - cu. ft. (liters)	2.84 (80)
Cycle Time - minutes	29-23 Minutes With Fill
Water Pressure - psi (Bar)	Pressure Fill - 20 to 120 psi (1.4/8.3)
Spin Speeds - RPM	500, 650, 1000
Motor HP	Multi-speed, 1 HP
Top Finish	Porcelain
Electrical Specifications and Circuit Requirements	120/60/1 - 15 amp
Color	White
Net Weight - lbs (kg)	240 (109)
Shipping Weight - lbs (kg)	260 (118)
Agency Approvals	cULus

At Speed Queen, we're so confident that our heavy-duty commercial washers and dryers are Commercial Built to Last Longer, that we're offering the following limited warranty to prove it:

Through three years† — Any part of the washer, dryer or stack dryer. Through five years† — The washer transmission assembly, base and cabinet assembly including top, lid and door, against rust from inside out. Lifetime† — The stainless steel washtub.

†Parts only. Labor not included. See Speed Queen Warranty Bond for specifics.

For the most accurate information, the installation guide should be used for all design and construction purposes. Due to continuous product improvements, design and specifications subject to change without notice. The quality management system of Alliance Laundry Systems' Ripon facility has been registered to ISO9001:2000.

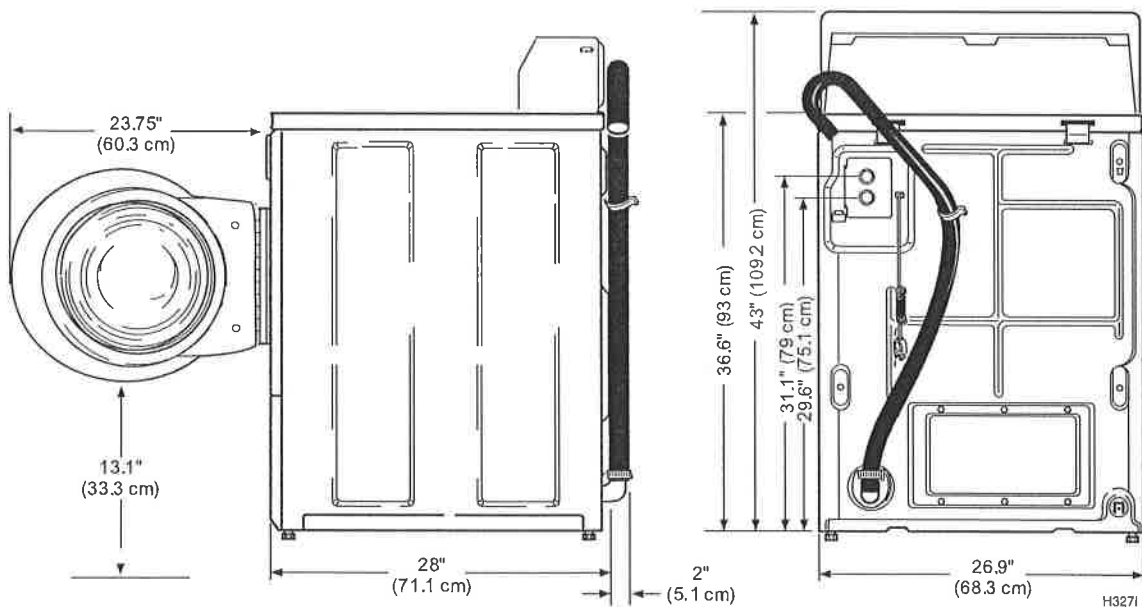

Speed Queen®

Multi-Housing



Card Ready

SDELYRGS17ITW01 (elec)

SDGLYRGS11ITW01 (gas)



Commercial Heavy-Duty Single Load Dryer

Description

- Extra-large digital displays
 - ~ Vend price preset \$2.00
 - ~ Cycle time
- LED cycle indicator
- Touch pad control with sound indicator
- Control panel selections
 - ~ High, Medium, Low, Delicate and No Heat
- Infrared two-way communication with pocket PDA
- Programming
 - ~ Cycle top-off extension
 - ~ Time-of-day promotions
 - ~ Laundry room shutdown
- Secured automated audits
 - ~ Cycle and card pulse
 - ~ Verifies collection activity
- Five heat cycle selections
- Factory default cycle 45 minutes
- **Activation - Debit or Card Payment**

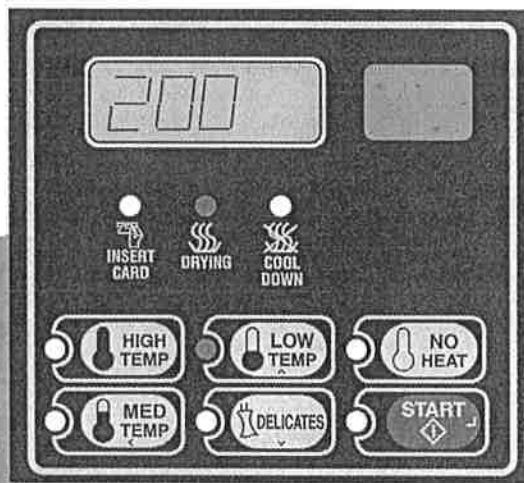

Nobody Compares with Speed Queen Quality

- Extra-large 7.0 cu. ft., 18 lb capacity galvanized steel cylinder.
- Wide door opening of 2.06 sq. ft. is the industry's largest, offering residents easy loading and unloading.
- Durable porcelain enamel top for long-lasting appearance.
- 100% serviceable from the front.
- Door is reversible for installation flexibility.
- Extended safety tumble for two minutes after cycle completion.
 - 20 minutes after cycle end.
 - Reduces wrinkling.



- Efficient dryer heating.
 - 5,350 W (elec models)
 - Also 4,750 W (208 V)
 - 25,000 Btu (gas models)
- High efficiency exhaust blower with superior airflow of 220 cfm.
- Up-front polyester lint filter is easy to clean and secured.
- Space-saving narrow cabinet (26 7/8" wide).



Commercial Built to Last Longer

Specifications

Model	SDELYRGS171TW01 (elec) SDGLYRGS111TW01 (gas)
Width - in (mm)	26 7/8" (683)
Depth - in (mm)	28" (711)
Height - in (mm)	43" (1092)
Dry Cycles	High, Medium, Low, No Heat
Cylinder Volume - cu. ft. (liters)	7.0 (198)
Btu Per Hour (kcal)	25,000 (6300)
Motor HP (Capacitor Start and Thermal Protected)	1/3 HP, 5.5 amps
Type of Gas (gas models only)	Factory-Equipped Natural/Mixed Gas Convertible to LP Gas+
Utility Connections - in (mm)	3/8" NPT (9.5)
Air Outlet Diameter - in (mm)	4" (102)
Exhaust Airflow - (liters/sec)	220 (105)
Maximum Exhaust Static Back Pressure	0.6" W.C.
Motor - RPM	60 Hz (1725)
Electrical Specifications Circuit Requirements	Elec 120/240/60/1 - 30 amp (171TW) 120/208/60/1 - 30 amp (151TW) Gas 120/60/1 - 15 amp
Colors	White
Net Weight - lb (kg)	Elec 135 (61) Gas 140 (64)
Shipping Weight - lb (kg)	Elec 145 (66) Gas 150 (68)
Agency Approvals	Elec CSA Star Gas cUL-us

At Speed Queen, we're so confident that our heavy-duty commercial washers and dryers are Commercial Built to Last Longer, that we're offering the following limited warranty to prove it:

Through three years† — Any part of the washer, dryer or stack dryer. Through five years† — The washer transmission assembly, base and cabinet assembly including top, lid and door, against rust from inside out. Lifetime† — The stainless steel washtub.

†Parts only. Labor not included. See Speed Queen Warranty Bond for specifics.

For the most accurate information, the installation guide should be used for all design and construction purposes. Due to continuous product improvements, design and specifications subject to change without notice. The quality management system of Alliance Laundry Systems' Ripon facility has been registered to ISO 9001:2000.

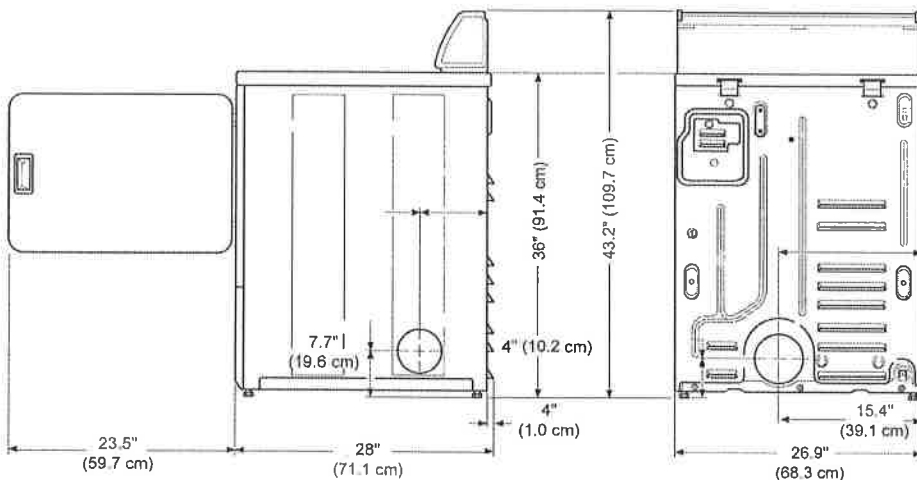

Temperature Selection	
Temperature	Setting
No Heat	Room Temp
Delicates	115°
Low	145°
Medium	155°
High	160°

AUTOMATIC LAUNDRY

September 18, 2013

Mr. Brian Milano
Imagineers, LLC
635 Farmington Ave.
Hartford, CT 06105

RE: Community Laundry Facilities at "The Westbury"

Dear Brian:

Thank you for giving us the opportunity to submit a proposal to upgrade the community laundry rooms at The Westbury in West Hartford, CT. After a review of the laundry rooms, we would like to replace the current coin-operated top load washers and dryers with our *Resident Advantage Card® Program*, which combines the use of laundry debit cards and new Speed Queen **Quantum™** front loading, high efficiency washers and dryers. Our *Resident Advantage Card®* provides residents with both a more reliable payment system and superior quality washers and dryers which offer residents greater cycle selection and superior cleaning and more efficient drying.

LAUNDRY EQUIPMENT

WASHERS: We will install 2013 High Efficiency (HE) Front loading washers: Speed Queen's new series of **Quantum™** HE front loading washers are **Energy Star qualified**, and provide properties with a better solution to managing their energy costs and laundry needs.

Quantum™ washers will reduce water consumption by using only 10.9 gallons of water per cycle as compared to 40 gallons with the current equipment. **Quantum™** front-loading washers have a full **eighteen (18#) pound capacity**. **Quantum™** washers have stainless steel inner and outer washtubs, a see through glass door and the largest door opening available. Whirlpool/Maytag front load washers only have a **sixteen (16#) pound capacity**; have a combination stainless steel and plastic inner washtub and a plastic outer washtub, which are not as durable.

The Speed Queen **Quantum™** front load washer is Energy Star Qualified and will reduce the cost of hot water by approximately **68% compared to your current washers**.

Quantum™ washers offers residents nine different wash cycles to choose from plus we can program up to eighteen additional "Premium". Other brands of front load washers only offer users up to six cycle selections.

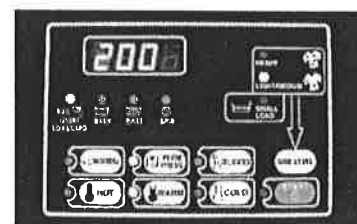
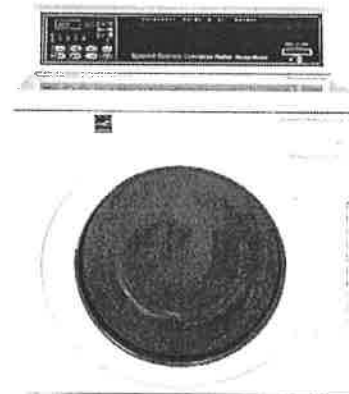

AUTOMATIC LAUNDRY

DRYERS: We will install 2013 Speed Queen Commercial **Quantum™** High Performance Dryers. **Quantum™** dryers provide five separate heat selections, "High" (cottons), "Medium"(perm press garments), "Low" (micro fiber garments), "Delicate" and "Fluff" (no heat). Maytag dryers have only three selections.

Quantum™ drying cylinders are made of brushed steel, and are more durable than powder paint coated drying cylinders, which other dryer manufacturers use. Speed Queen Dryers dry faster and have a larger load capacity because they have a **7.0 cubic foot cylinder (a full 18# capacity)** and generate a fan speed of 220 CFM. By combining higher fan speed with a larger drying cylinder, Speed Queen Dryers will dry more efficiently, and will reduce drying cost by approximately **31%**.

By being more energy efficient, Speed Queen Equipment will reduce energy costs!

Dryer Top-Off Cycle: Speed Queen Dryers feature a "Top-off" cycle, where residents can purchase additional drying time at anytime during the initial dry cycle.

Speed Queen Washers and Dryers are American made and manufactured in the Ripon, Wisconsin. By installing Speed Queen Washers residents will be selecting the most reliable, commercial grade washers and dryers available to the multi-housing industry. Speed Queen Washers and Dryers have been operating in community laundry rooms throughout the USA for over fifty years.

Equipment Replacement Policy: Automatic Laundry will replace any washer or dryer, which the community feels is not operating properly. We are committed to providing residents with the best laundry equipment and service available.

Hours of Operation: **Quantum™** washers and dryers can be programmed to automatically turn themselves off each night, and then turn themselves back on again each morning, thus assuring that residents will not use the equipment between certain hours each evening. If you would like us to implement this feature please tell us the times of operation you would like.

Dryer Venting: Proper dryer ventilation is critical to insure that dryers work efficiently and properly. The venting set up in your rooms is ideal and our installation crew will install rigid venting from the back of the dryer to the inside wall connections. **We do not use flexible venting which can trap lint and dent easily.**

With properly maintained dryer vents, Speed Queen's high fan speed and larger capacity we will be able to reduce drying times. Residents will appreciate the ability to process their laundry faster and with less work. Shorter drying times will benefit the property because utility costs will be reduced and customer satisfaction will be increased.

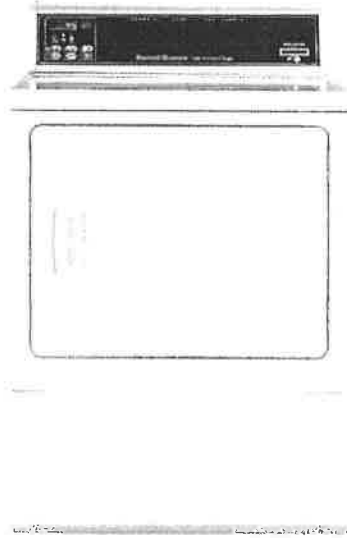

AUTOMATIC LAUNDRY

Multi-Level Vend Pricing: One of the biggest benefits available to communities which select **Quantum™** washers and dryers is the system's ability to charge a different price for wash cycles based on the water temperature selected. We are able to charge different prices for wash cycles which use "HOT" water, "WARM" water and "COLD" water. "HOT" and "WARM" water wash cycles are more costly cycles for a community to pay for and consume more energy than "COLD" water wash cycles therefore it makes sense to charge more for those cycles which use electricity or gas to heat the water. Our Multi-Level Vending pricing feature promotes conservation by charging less for "COLD" water cycles. Hot and warm water usage is reduced.

Premium Vend Pricing: In addition to our Multi-Level Vending feature, we can offer the Association additional "**Premium**" cycles. These "**Premium**" cycles are based on soil levels and offer residents a "MEDIUM" wash option which offers residents an additional rinse cycle and a "HEAVY" wash option which offers residents a prewash and an additional rinse cycle. The "Normal" nine wash selections are referred to as "LIGHT SOIL". There are additional charges for the "MEDIUM SOIL" wash option and for the "HEAVY SOIL" wash option.

Collection Protection: **Quantum™** laundry equipment exclusively features a computerized Auditing system which cannot be reset or manipulated. In addition, our Add Value Machine tracks every transaction in detail. Accompanying each and every Automatic Laundry "Rent" check to the Association is a statement detailing the collection date, Collection period, gross collections, and the association's share of collections.

SERVICE

Since 1964, Automatic Laundry has been providing prompt, professional service throughout the Northeast. Our reputation for our service responsiveness and performance is highly regarded by the leading property management companies and condominium associations.

www.automaticlaundry.com: In addition to calling our 24 hour service number, residents can visit our web site to request service on-line, obtain refunds, learn how to do their laundry, and how to properly use the equipment simply by visiting our website.

Service: Service requests will be repaired within **six business hours** during regular workdays. The service department is in constant contact with each service truck. Our dispatching system, in combination with GPS tracking technology, allows our service managers to efficiently dispatch all service requests.



All of our service trucks are completely outfitted with a full complement of parts, so that repairs can be made on the first visit. You will never have a machine out of order because we are waiting for parts.

AUTOMATIC LAUNDRY

CASH-LESS PAYMENT SYSTEM

Automatic Laundry has deployed thousands of cash-less, smart card laundry payment systems and offers the latest in secure transactions and flexible payment options.

Payment System: Debit/Credit Card and Code to Laundry Card:

Residents will insert either a Visa, MasterCard or bank Debit card into the Add Value Station, choose an amount and the value will be added onto the laundry cards. The Add Value Station will be placed at a central location making it very convenient for the residents to add value to their cards. A clear, color LCD with bright graphical instructions make it convenient for residents to add value to their card, purchase new cards, or get refunds. A paper receipt is provided as an option.

Our Resident Advantage® credit/debit system is much more reliable and residents will not experience “denied” or “failed” card transactions which can be reoccurring problems with other systems.

The Add Value Station will use our cell phone based technology for reliable transactions and only requires a standard 115 volt electrical outlet.



Code to Card: An added benefit to our system is that we also can offer residents the ability to add value to their laundry cards via our secure and easy to use website (www.revaluemycard.com/automaticlaundry). Residents who choose to do so can simply log on to our secure website and register their laundry card onto our system and then using their credit or debit card they can purchase additional value for their laundry card. Our system will issue them a secure “Value” code. Residents then take their laundry card and the “Value” code to the Add-Value Station and insert the card into the Add-Value Station and then input the “Value” code via the key pad and instantly the value you purchased via our website is placed onto your laundry card. Residents who do not have internet access, or do not have a credit or debit card can add value to their cards by mailing a check or money order to our offices. Or, if they wish to pay by phone, they can call our office and give us their credit card number and one of our helpful Card Administrators, who will issue the resident a secure “Value” code.

Upon installation each residential unit will be given one of our Resident Advantage Card® FREE with a complimentary value of \$4.00, good for 1 free wash and 1 free dry. This is a value of over \$1,000.00 for the Association.





Immediate Refunds: The “Code to Card” feature of our **Resident Advantage®** system allows our Laundry Card Administrators to issue refunds immediately by phone or email. We issue residents a “REFUND” code, which residents can immediately redeem by inserting their laundry card into the Add Value Station and then entering the “Refund” code on the key pad and the value of the refund will be placed back on the resident’s laundry card.

Push to start button: This new feature now allows residents to check the balance on their **Resident Advantage Cards®** at each washer and dryer without starting the laundry equipment. Residents do not have to use the Add-Value unit to check balances. The display on the machine will automatically show current card balances, count down the vend price and then show the remaining card balance. The display will also show the time remaining on the cycle, a real convenience.

ROOM DÉCOR

Room Accessories: We will provide the following in each laundry at our expense:

- 1) Brightly colored instructional signs, featuring our 24-hour service number and our web address to request service on-line
- 2) Stainless steel hot and cold water fill hoses to prevent flooding.
- 3) Molded fiberglass laundry folding tables
- 4) New Galvanized rigid dryer venting

REVENUE SHARING PROGRAM

Item	Description	
New Speed Queen Quantum™ Laundry Equipment	12-HE Front Load Washers 12-Dryers	
Secure, Cashless Payment System	<i>Resident Advantage®</i> Heartland Wavepoint Micro Credit/Debit/ATM/Code with immediate refunds Cell phone based PCI compliant	
Base Vend Prices	\$1.75- Front Load Washer/\$1.95 Heavy Cycle \$1.75-18# Dryer/\$0.25 Top off 10 minutes	
Financial	Option 1	Option 2
Commission Payment	50% of laundry income	55% of laundry income
Remodeling Check	\$5,00.00	\$3,000
Lease Term	10 Years	10 years

AUTOMATIC LAUNDRY

Open House: to better acquaint the residents with our new *Resident Advantage*® system and the new **Quantum**™ washers and dryers, we will hold an open house for the residents of The Westbury during which we will demonstrate how to use the new system and answer any questions the residents may have. We will provide free laundry detergent samples and refreshments.

We would appreciate the opportunity meet with you to review our proposal and ultimately negotiate a mutually beneficial agreement. I believe our laundry room management program will greatly benefit your residents with increased convenience and improved satisfaction having new, energy efficient laundry equipment with the latest in technology on site. I look forward to working with you to provide your association with the best laundry facilities available.

Option Selected: _____

Offered by:



Doug E. Lindland
District Manager

Date: 9/18/2013

Accepted by:

Date: _____